



# PSI

# Volleyball

- 
- STORY TIME
  - THE COURT AND AREAS
  - NET PLAY
  - THE SERVE



# To Do List

---

- Update your blocks
- Accept or Decline games
- Contact your partner.

# Declined Reasons (from FB & VB)

---

It's my birthday I'll be out of town

Out of town

Work @ 3pm

I am teschibg at Harbor High until 3:35 M-F

# 2023-24 Training

---

~~Meeting 1 - Tuesday, July 18 - Zoom~~

~~Meeting 2 - THURSDAY, Aug 3 - In Person~~

Meeting 3 - Tuesday, Aug 8 - Zoom

Meeting 4 - Tuesday, Aug 15 - In Person

5 quizzes (count as 1 meeting)

Sportsmanship Game or Jamboree = 1 meeting. (Aug 19, 21)

# Jamborees – Sat, Aug 19

---

Varsity – 9 AM Soledad HS – Kevin Long & Larry Eady

JV – 9 AM Alvarez HS

JV – 9 AM Monte Vista Christian School

Frosh – 9:30 AM Watsonville HS (1)

# Sportsmanship Matches – Mon 8/21

---

Marina @ Monterey

Alvarez @ N. Salinas

Christopher @ Gilroy

Alisal @ Salinas

# Certification Exam

---

80% to pass

Mandatory for post season assignments

Only 7 people have completed the exam so far.



# Quizzes

---

Designed to get you thinking about volleyball

Participation counts: Completing all 5 quizzes counts as attending a meeting.

They're pretty easy, but read the question!

Quizzes 1-3 and the Certification Exam are available now.

Arbiter > PSI Central Hub > Testing

Lance Null (Official)  
PSI (101441) ▾



ArbiterSports, LLC	1099
Official	
<b>BASO</b>	112833
Official	
Central Hub	
<b>CCAA-VB</b>	106315
Official	
<b>CCSOA</b>	105049
Official	
<b>CIF Playoffs</b>	102268
Official	
<b>NCAA Volleyball</b>	106897
Official	
<b>PSI (New)</b>	101441
Assigner	
Central Hub	
Official	
<b>PSI (Old-Do Not Use)</b>	101440
Central Hub	
<b>The Org</b>	103886
Official	



Testing Help ?

Pending Tests

	Group	Start Date	Start Time	Close Date
<b>2023-24 Volleyball Quiz #4 - Player Equipment and Uniform</b> <small>Opens in: 03 Days , 11 Hours , 42 Minutes</small>	psi	08-12-2023	12:01 AM	08-31-2023
<b>2023-24 Volleyball Quiz #5 - Case Plays</b> <small>Opens in: 08 Days , 11 Hours , 42 Minutes</small>	psi	08-15-2023	12:01 AM	09-06-2023

Open Tests

	Group	Close Date	Max Attempts	Status																	
<b>2023-24 Volleyball Quiz #3 - Game Equipment</b> <small>You may take this test 1 more time(s). Time Remaining: 13 Days , 11 Hours , 39 Minutes</small>	psi	08-21-2023	2	Not Started	<a href="#">Instructions</a>	<a href="#">Take Test</a>															
<table border="1"> <thead> <tr> <th colspan="5">Attempts</th> </tr> <tr> <th>#</th> <th>Answered</th> <th>Score Result</th> <th>Completed On</th> <th>Review</th> </tr> </thead> <tbody> <tr> <td>1</td> <td>5 of 5</td> <td>100% Passed</td> <td>08-07-2023</td> <td></td> </tr> </tbody> </table>							Attempts					#	Answered	Score Result	Completed On	Review	1	5 of 5	100% Passed	08-07-2023	
Attempts																					
#	Answered	Score Result	Completed On	Review																	
1	5 of 5	100% Passed	08-07-2023																		
<b>2023-24 Volleyball Quiz #1 - The Game</b> <small>You may take this test 1 more time(s). Time Remaining: 13 Days , 11 Hours , 39 Minutes</small>	psi	08-21-2023	2	Not Started	<a href="#">Instructions</a>	<a href="#">Take Test</a>															
<table border="1"> <thead> <tr> <th colspan="5">Attempts</th> </tr> <tr> <th>#</th> <th>Answered</th> <th>Score Result</th> <th>Completed On</th> <th>Review</th> </tr> </thead> <tbody> <tr> <td>1</td> <td>7 of 7</td> <td>100% Passed</td> <td>07-20-2023</td> <td><a href="#">Review your test</a></td> </tr> </tbody> </table>							Attempts					#	Answered	Score Result	Completed On	Review	1	7 of 7	100% Passed	07-20-2023	<a href="#">Review your test</a>
Attempts																					
#	Answered	Score Result	Completed On	Review																	
1	7 of 7	100% Passed	07-20-2023	<a href="#">Review your test</a>																	
<b>2023-24 Volleyball Quiz #2 - The Court</b> <small>You may take this test 1 more time(s). Time Remaining: 13 Days , 11 Hours , 39 Minutes</small>	psi	08-21-2023	2	Not Started	<a href="#">Instructions</a>	<a href="#">Take Test</a>															
<table border="1"> <thead> <tr> <th colspan="5">Attempts</th> </tr> <tr> <th>#</th> <th>Answered</th> <th>Score Result</th> <th>Completed On</th> <th>Review</th> </tr> </thead> <tbody> <tr> <td>1</td> <td>6 of 6</td> <td>100% Passed</td> <td>07-30-2023</td> <td><a href="#">Review your test</a></td> </tr> </tbody> </table>							Attempts					#	Answered	Score Result	Completed On	Review	1	6 of 6	100% Passed	07-30-2023	<a href="#">Review your test</a>
Attempts																					
#	Answered	Score Result	Completed On	Review																	
1	6 of 6	100% Passed	07-30-2023	<a href="#">Review your test</a>																	
<b>2023 Volleyball Test Part A</b> <small>You may take this test 2 more time(s). Time Remaining: 24 Days , 11 Hours , 39 Minutes</small>	psi	09-01-2023	3	Not Started	<a href="#">Instructions</a>	<a href="#">Take Test</a>															
<table border="1"> <thead> <tr> <th colspan="5">Attempts</th> </tr> <tr> <th>#</th> <th>Answered</th> <th>Score Result</th> <th>Completed On</th> <th>Review</th> </tr> </thead> <tbody> <tr> <td>1</td> <td>50 of 50</td> <td>100% Passed</td> <td>07-20-2023</td> <td><a href="#">Review your test</a></td> </tr> </tbody> </table>							Attempts					#	Answered	Score Result	Completed On	Review	1	50 of 50	100% Passed	07-20-2023	<a href="#">Review your test</a>
Attempts																					
#	Answered	Score Result	Completed On	Review																	
1	50 of 50	100% Passed	07-20-2023	<a href="#">Review your test</a>																	

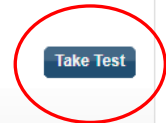
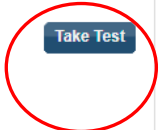
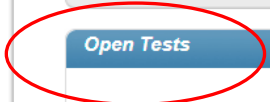
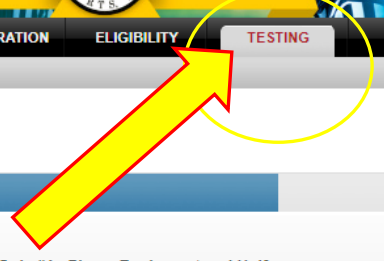
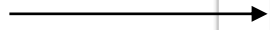
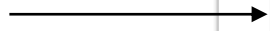

# Tournaments – Dates (so far)

---

Arbiter:

Aug 26	St. Francis SCP	Varsity	8am, 1pm shifts (0/1)
Sept 2	Watsonville	JV	7:30, 12:30 shifts (4/4)
Sept 23	Watsonville	Frosh Soph	7:30, 12:30 shifts (4/4)
Sept 30	Rancho San Juan	Varsity	8am, 12:30 shifts (4/4)

CCS Approved:

Sept 30	N. Salinas	Frosh Soph
Oct 7	Watsonville	Varsity



# Prematch Timing

---

# PCAL Matches

---

1<sup>st</sup> match of the night:

22 min on the clock.

Coach & Captains meeting / coin toss ([Roster due to R2](#))

22:00 – 12:00 Shared Court

12:00 – 6:00 Serving team has court

6:00 - :00 Receiving team has court ([Lineups due at 2:00](#))

:00 Lineups checked and First Serve

# PCAL Matches

---

additional match(es) of the night:

12 min on the clock.

Coach & Captains meeting / coin toss (Roster due to R2)

12:00 – 6:00 Serving team has court

6:00 - :00 Receiving team has court (Lineups due at 2:00)

:00 Lineups checked and First Serve



# BVAL Matches

(Gilroy, Christopher, Live Oak, Sobrato, etc.)

---

30 min on the clock, start clock

Coach & Captains meeting / coin toss ([Roster due to R2](#))

30:00 – 15:00 Shared Court

15:00 – 9:00 Serving team has court

9:00 – 3:00 Receiving team has court

3:00 - :00 Announcements, Anthem, etc. ([Lineups due at 2:00](#))

:00 Lineups checked and First Serve



# Between sets (Non-deciding set)

---

3 min on the clock, start clock.

R2 gets lineup sheets to coaches (if they haven't already retrieved them)

Game ball back to table

Lineups due at 1 minute

30 sec – warning whistle by R2 (or R1)

:00 Lineups are checked and first serve.

# Between sets (Deciding set)

---

3 min on the clock. DO NOT START.

Coin toss, Home team calls

R2 indicates to R1 which team will serve first. (Don't leave them hanging...)

Clock starts

Game ball back to table, Lineup sheets to coaches.

Lineups due at 1:00

30 sec – warning whistle by R2 (or R1)

:00 Lineups are checked and first serve.



# Story Time

---

THINGS I'VE SCREWED UP (OR WATCHED, OR HEARD FROM  
OTHER OFFICIALS) AND WE CAN ALL LEARN FROM

# Libero Serving

---

The Team S libero has not served in the current set. Player #10 is supposed to serve next. The libero replaces #15, and goes to the service area. The team scores 1 point, and then scorer notifies the R2 that the wrong server served.

Now what? Do we adjust the score? Is the libero locked into this serving spot (for #10) for the remainder of the set?

Palma @ N. Salinas 2022

# Libero Serving

---

The Team S libero has not served in the current set. Player #10 is supposed to serve next. The libero replaces #15, and goes to the service area. The team scores 1 point, and then scorer notifies the R2 that the wrong server served.

The point is removed from Team S, and a side out is awarded. (This is noted with a square on the score sheet).

But since the libero did not replace a legal server, the libero has not served yet and may subsequently serve in any position. (In this case, for #15 as the coach planned).

Case 6.4.2 Sit A



# Libero Replacement - Injury

---

The libero is injured during play. It is determined that the libero cannot continue, and will be replaced.

How long does the coach have to re-designate a libero?

Can the coach designate a new libero immediately, and replace the injured libero with the new libero?

Why does all the weird stuff happen with liberos?

Palo Alto @ St. Francis – Set #5, 2020

# Libero Replacement - Injury

---

The libero is injured during play. It is determined that the libero cannot continue, and will be replaced.

How long does the coach have to re-designate a libero? 10-4-3

Redesignation does not need to occur immediately, but may occur at the discretion of the coach.

Any substitute may be designated as the libero for the injured libero.

The new libero must wear (change into) a libero jersey and remain the libero for the remainder of the set.

# Libero Replacement - Injury

---

The libero is injured during play. It is determined that the libero cannot continue, and will be replaced.

Can the coach designate a new libero immediately, and replace the injured libero with the new libero? 10-4-3

# Libero Replacement - Injury

---

The libero is injured during play. It is determined that the libero cannot continue, and will be replaced.

Can the coach designate a new libero immediately, and replace the injured libero with the new libero? 10-4-3

**No.** The libero must be replaced by the player he/she replaced. This is the libero replacement for this dead ball. The new libero may replace the player after the next completed rally.

# Libero Dig

---

Team A attacks with a hard driven ball thru a block. The Team B libero, who is straddling the attack line, digs the ball with overhand action (maybe in self defense) and ball deflects above the height of the net. Then:

A. The setter dumps the ball over the net.

B. An attacker kills the ball.

C. An attacker hits the ball which is blocked back into Team B's back row.

D. An attacker hits the ball into the net, and the setter digs it up and over with a free ball to Team A.

E. There is a joust at the net.

# Libero Dig

---

This can be difficult in real time – it happens so fast!

The keys to this are:

Recognizing the Libero has “set” the ball using overhead finger action.

Determining if the libero is on/in front of the attack line, or behind it.

- Easier on a dink over the block, harder on a reaction dig from a driven ball.

Determining if a legal attack has been completed.

Your R2 may be able to help you!

# Libero Dig

---

Team A attacks with a hard driven ball thru a block. The Team B libero, who is straddling the attack line, digs the ball with overhand action (maybe in self defense) and ball deflects above the height of the net. Then:

A. The setter dumps the ball over the net.

**Illegal attack, charged to the libero.**

B. An attacker kills the ball.

**Illegal attack, charged to the libero.**

C. An attacker hits the ball which is blocked back into Team B's back row.

**Illegal attack, charged to the libero.**

# Libero Dig

---

Team A attacks with a hard driven ball thru a block. The Team B libero, who is straddling the attack line, digs the ball with overhand action (maybe in self defense) and ball deflects above the net. Then:

D. An attacker hits the ball into the net, and the setter digs it up and over with a free ball to Team A.

**Legal – play continues.** (There was no completed attack on the next hit.)

E. There is a joust at the net.

**Illegal attack, charged to the libero.** The simultaneous contact counts as a completed (and legally blocked) attack.



# Wrong Server...

---

For simplicity sake, we'll call the order 1,2,3,4,5,6

1 served

2 served

4 served, not detected out of order

5 served, still not detected

6 served, scored 2 points, and then the table informs R2 that the wrong server is serving.

Now what?

Marina Summer League 2023

# Wrong Server...

---

For simplicity sake we'll call the order 1,2,3,4,5,6

6 served, scored 2 points, and then the table informs R2 that the wrong server is serving.

We act on the current wrong server, and cannot change any thing for the previous servers.

- Cancel the 2 points due to a wrong server.
- Have the team back rotate to put 5 in the RB position, and 6 will be the next server.

Ideally we catch this earlier, but we didn't.

# What do you have to do to get ejected?

---



# What do you have to do to get ejected?

---





# The Court and Areas

---

WHAT AND WHERE

# The Court

---

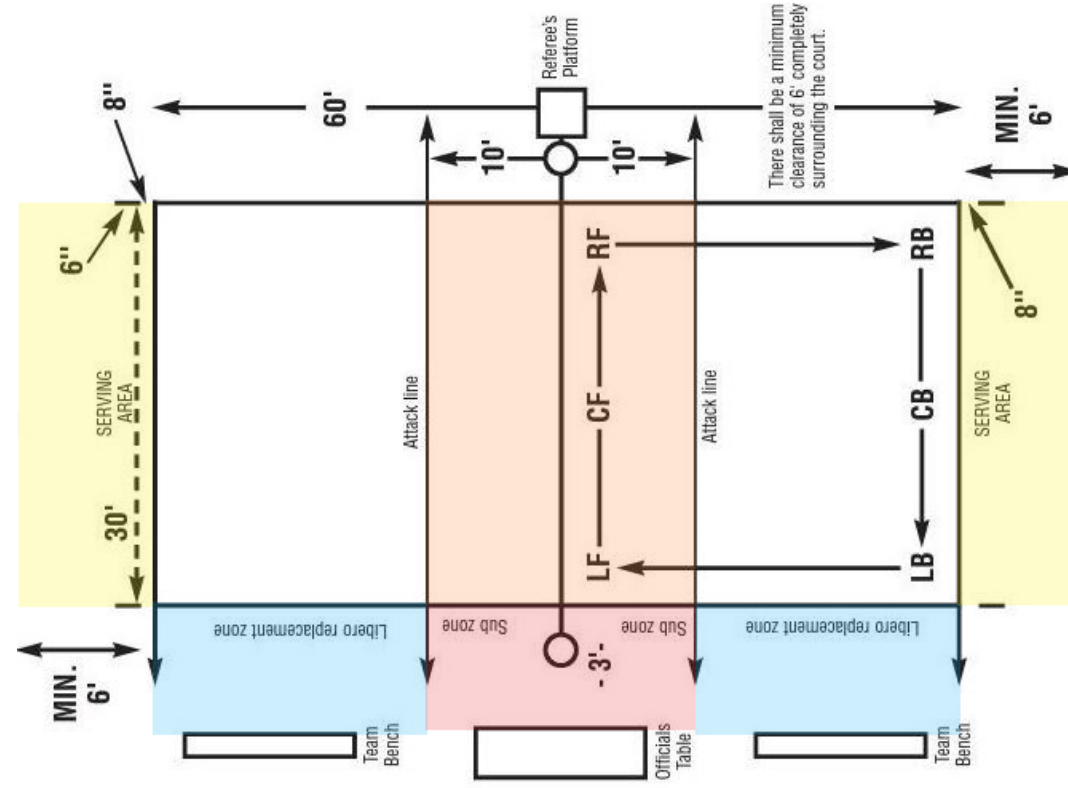

# Lines

---

**Boundary lines** are part of the court (entire line is in)

**Center line** divides the court into two equal sides

- Must be a continuous line.
- May be solid, shadow bordered, or a combination.
- Logo should not distract from line visibility.
- Put down tape if necessary on the center line

**Attack line** – 10' from axis of center line.

- Entire line is in the attack zone



# Substitution Zone

---

The area near the sideline between the attack line and the center line.

THIS IS THE R2'S AREA –  
**KEEP THE COACHES OUT**

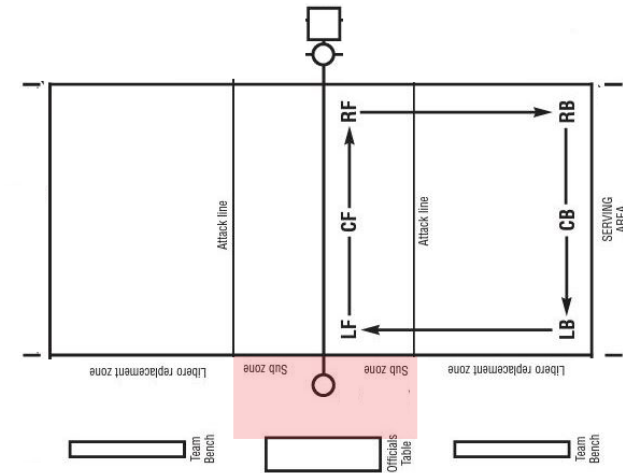

# Libero Replacement Zone

---

The area near the sideline between the attack line and the end line.

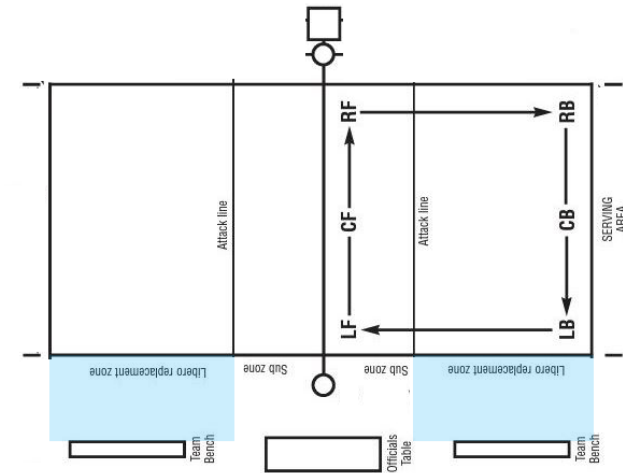

# Service Area

---

Behind and excluding the end line.

Laterally limited by two short lines, which are included in the serving area.

Minimum of 6 feet deep.

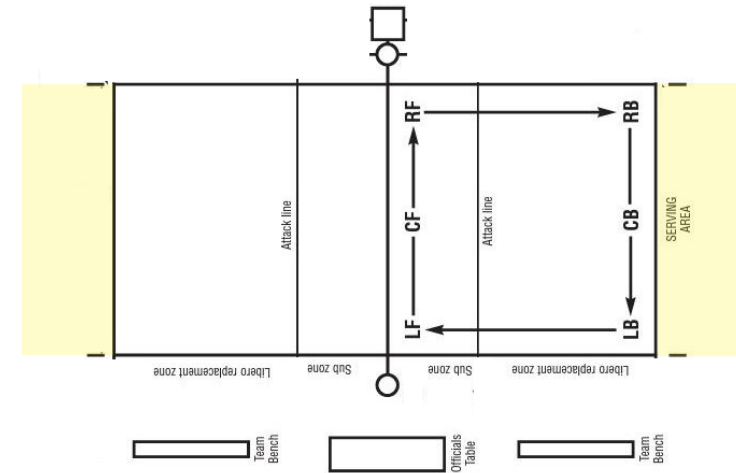

# Playable Area

---

Includes the court and the unobstructed space outside of the court boundary lines.

Shall be visible to all team members and officials

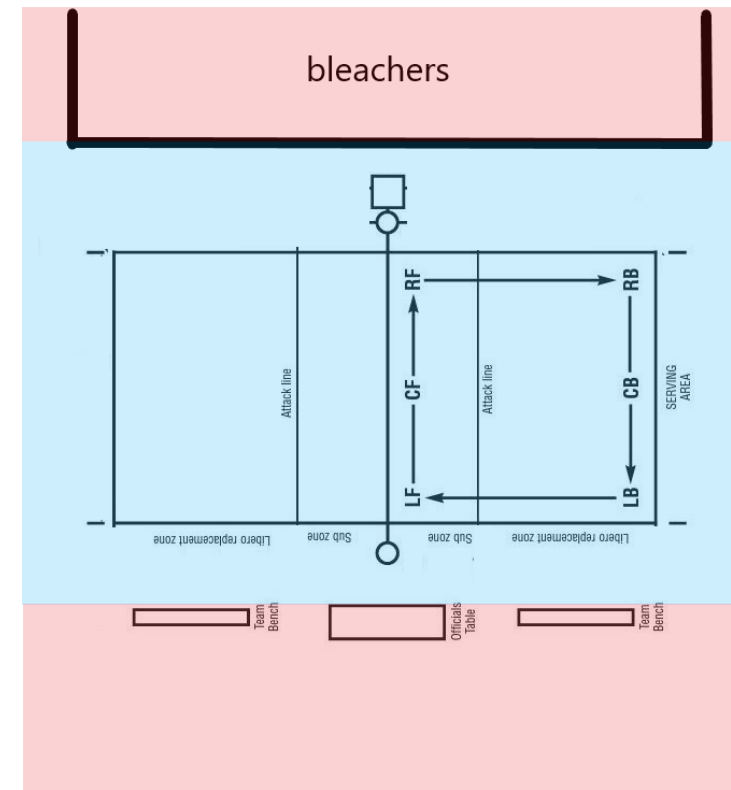

# Playable Area

---

Player must be in contact with the playable surface to play a ball over a nonplayable area.

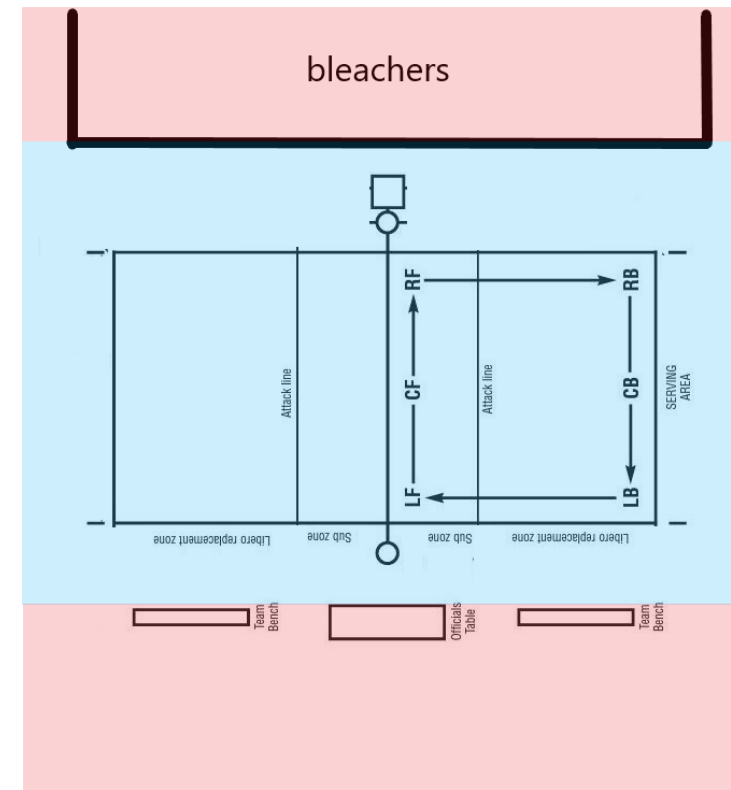

# Nonplayable Area

---

Space located beyond the playable area.

It includes walls, bleachers, team benches, area behind the benches, and any other areas identified in the pre-match conference.

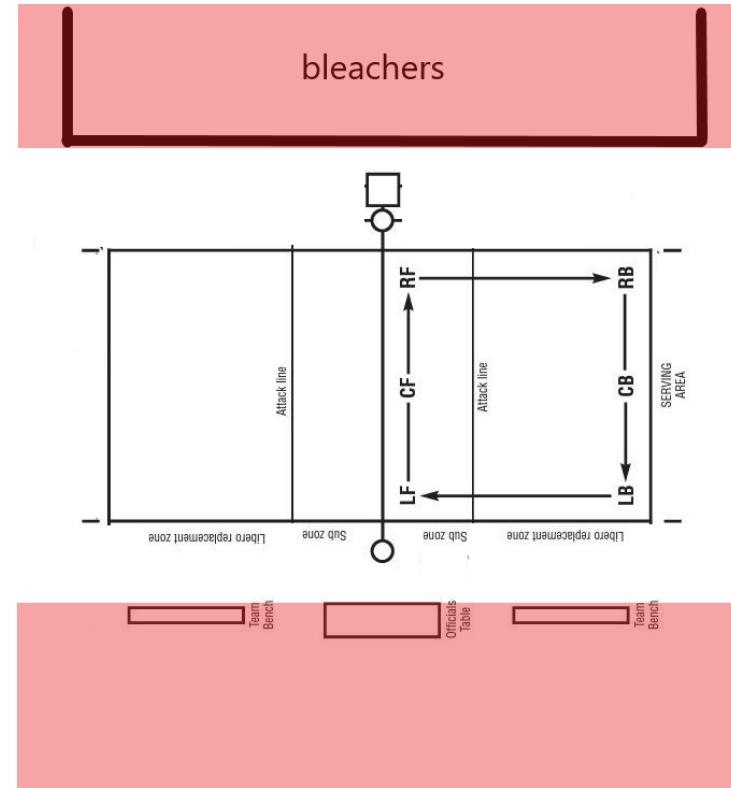

# Nonplayable Area

---

Teams may warm up in nonplayable areas, but may not use balls to warm up.

Teams may remove/change jerseys in nonplayable areas.

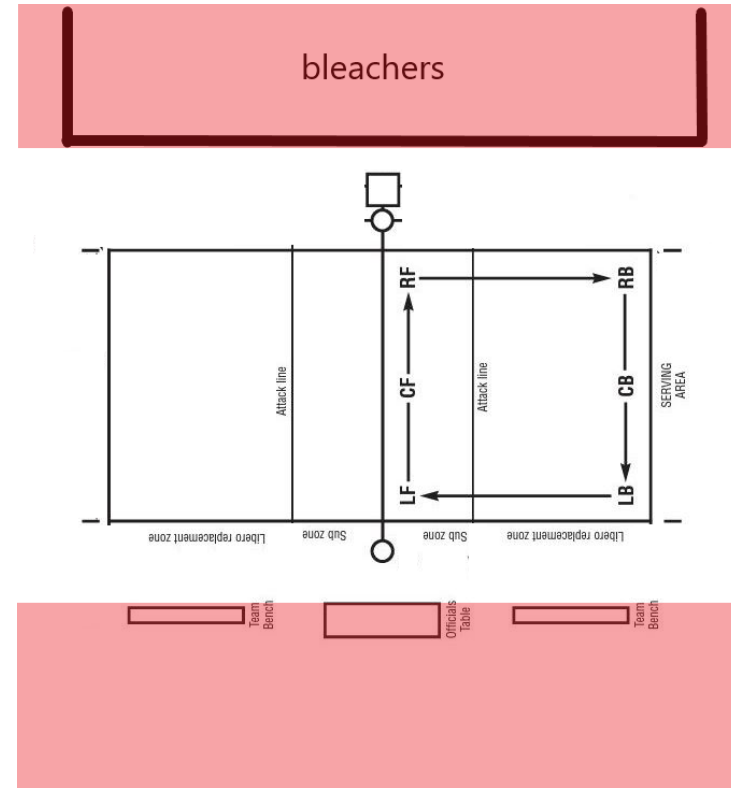

# Where Can Non-Players Stand?

---

Players may stand in the warmup area during the match.

Beyond the end of the bench or behind the bench, but NOT in front of the bench.

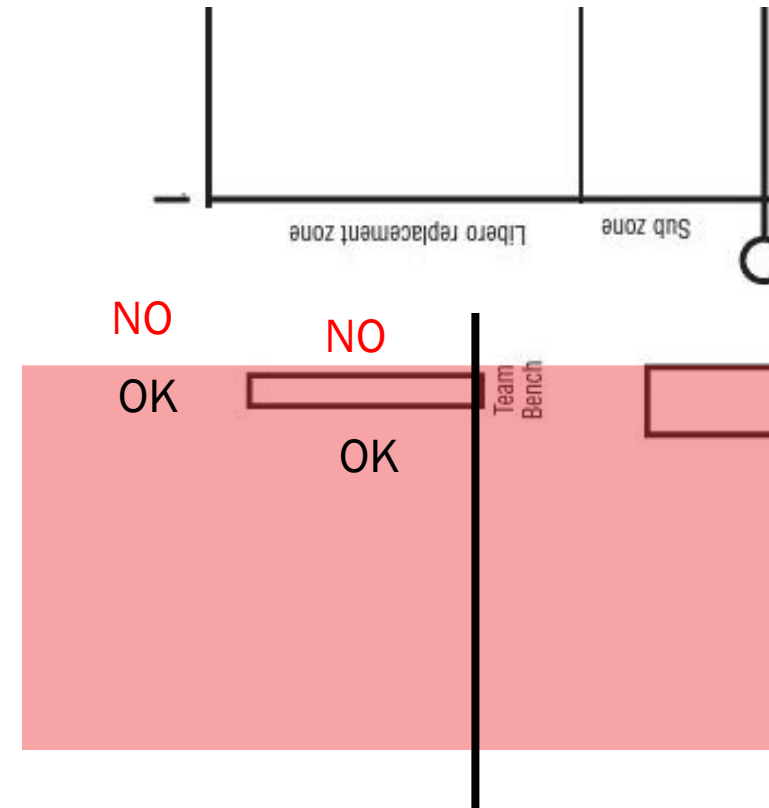



# Coaches Area **NEW**

Head coach may stand in coaches area. Cannot designate.

1 assistant coach may stand in coaches area during dead ball.

During play, must stand no closer than 6' from sideline

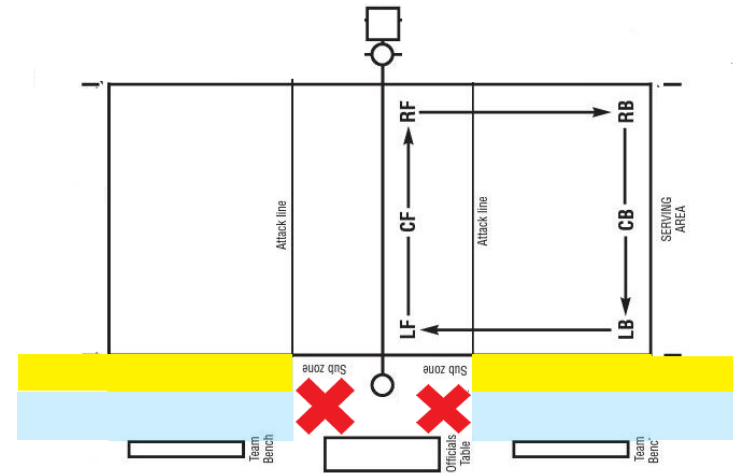





# Rosters and Lineups

---

Rosters are due at the pre-match coin toss.

Rosters are submitted to the R2.

(Any corrections to roster under 10 minutes, or for an unlisted player to enter a set : Administrative Red – Point / loss of rally when discovered)

(7-1 Pen 2,3)

# Rosters and Lineups

---

Lineups are due 2 minutes before the first set and 1 minute before each subsequent set.

(Penalty for late lineup: Unnecessary Delay : Administrative **Yellow** card) (7-2 Pen 1&2)

If lineup is not submitted before the end of the timed warmup or intermission, the penalty is a second unnecessary delay, and Administrative **Red** card. (7-2 Pen 1&2)

# Lineup Sheet

---

Lists players in serving order

Can be on a pre-printed form, or written on a piece of notebook (or any scrap of) paper.

Check for libero # and captain

Team: <u>Tigers</u>	Game: <u>1</u>
Libero: <u>5</u>	CHECK ONE: <input checked="" type="checkbox"/> Serve <input type="checkbox"/> Receive
<u>I</u>	<u>3</u>
<u>II</u>	<u>7</u>
<u>III</u>	<u>4C</u>
<u>IV</u>	<u>1</u>
<u>V</u>	<u>9</u>
<u>VI</u>	<u>2</u>



# Lineup Check

---

Receiving team, then serving team. (Unless serving team is ready before receivers.)

Signal libero to enter.

Point out captain to R1.

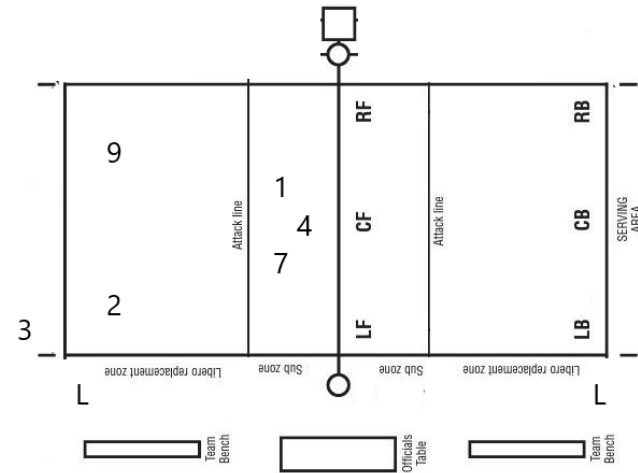



# Lineup Check

---

## Receiving Team

First player listed is in the right front position. (Will rotate into service)

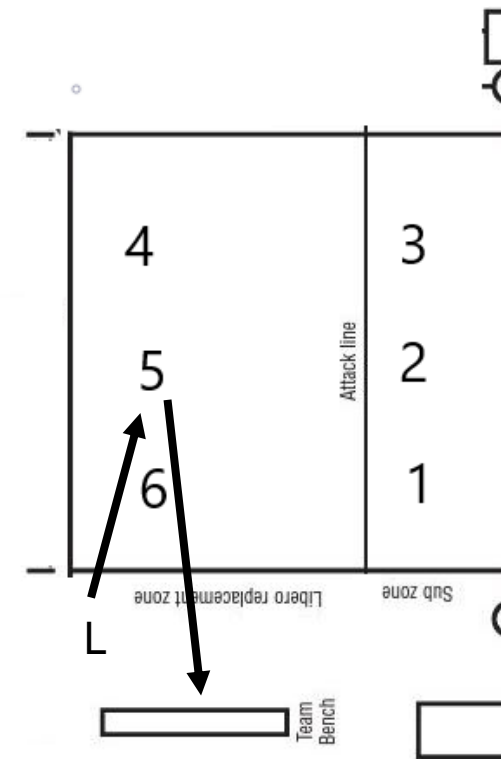

# Lineup Check

---

Serving Team

First player listed is in the right back position.

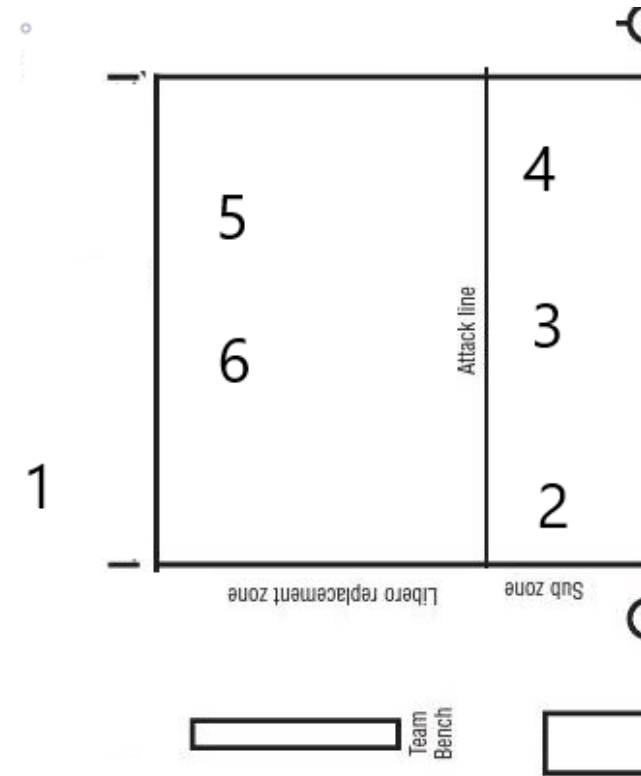



# Net Play

---

# Block

---

What is a block?

(hint – there are 3 elements)

Defined in 9-5-1c



# Block

---

The action of a player(s) close to the net that deflects the ball coming from the opponent by reaching higher than the top of the net at the moment of contact.

A block may involve wrist action provided there is no prolonged contact



# Block

---

**Block Attempt** – the action of blocking without touching the ball. An attempt to block does not constitute a block.

**Completed block** – when the ball is touched by a blocker. Only front row players are permitted to complete a block.

**Collective block** – a block executed by more than one blocker in close proximity. It is completed when one of the players touches the ball. It is a blocking fault if a back-row player or libero participates in a completed collective block.

# Net Play Basics

---

Blocking a served ball is not permitted (9-6-5)

Attacking a serve completely above the height of the net is not permitted. (9-6-6)

- However, the contact is legal, and the ball is not out of play until it completely crosses the vertical plane of the net or is legally contacted by an opponent.



# Net Play Basics

---

Ball must cross entirely within the net antennas.

A ball may be attacked, excluding a served ball, when it has partially crossed the net.

# Net Play Basics

---

Cannot contact a ball on the opponents side of the net, unless it is a legal block

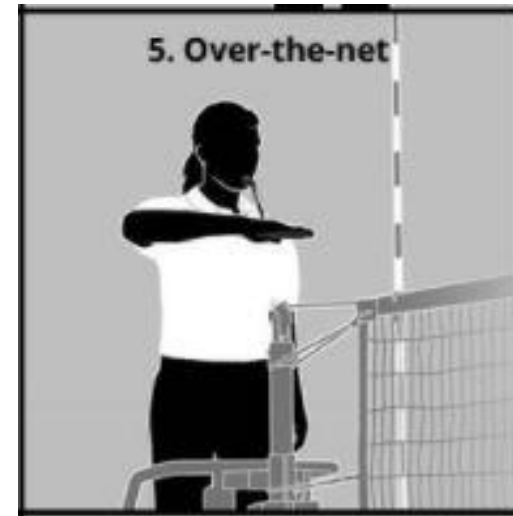

# Net Play Basics

---

Blocking a ball on the opponent's side of the net is permitted:

- Attacking team has completed its 3 hits
- Attacking team has had the opportunity to complete the attack, or directs the ball toward the opponent's court
- Ball is falling near the net and no attacker can make a play.



# Net Play Case Play

---

Team R overpasses the ball. The setter:

A) reaches over the net and sets the ball, which is completely on Team S's side of the net, to a teammate.

B) reaches above the net and sets the ball, which is above the net, to a teammate.

Ruling ?

# Net Play Case Play

---

Team R overpasses the ball. The setter:

A) reaches over the net and sets the ball, which is completely on Team S's side of the net, to a teammate.

**Over-the net violation.**

B) reaches above the net and sets the ball, which is above the net, to a teammate.

**Legal.** Play continues.

# Net Play Case Play

---

Team R overpasses the ball. The back row setter reaches above the plane of the net to set the ball:

A) Blocker S1 blocks the ball into the setter's hand.

B) Blocker S1 blocks the set while it is still in the plane of the net.

Ruling ?

# Net Play Case Play

---

Team R overpasses the ball. The back row setter reaches above the plane of the net to set the ball:

A) Blocker S1 blocks the ball into the setter's hand.

**Illegal Back Row Block**

B) Blocker S1 blocks the set while it is still in the plane of the net.

**Illegal Back Row Attack**

# Net Play Basics

---

## Joust

When two opponents cause the ball to momentarily come to rest above the net through simultaneous contact.

The player on the opposite side of the net from which the ball falls shall be considered the player to have touched the ball last.





# Joust Case Play

---

Two opposing players joust as it breaks the plane of the net following the third hit by team S.

Ruling ?

# Joust Case Play

---

Two opposing players joust as it breaks the plane of the net following the third hit by team S.

Ruling: **Four hits by Team S.** Point Team R

# Joust Case Play

---

Two opposing players joust as it breaks the plane of the net following the second hit by team S.

A) The ball falls out of bounds on Team R's side.

B) The ball rolls along the top of the net and into the antenna.

Ruling ?

# Joust Case Play

---

Two opposing players joust as it breaks the plane of the net following the second hit by team S.

A) The ball falls out of bounds on Team R's side.

Point Team R.

B) The ball rolls along the top of the net and into the antenna.

Replay.

# Net Fault Signal

---



Signal 6

Hand of outstretched arm on the side of the net on which the fault occurred.

(You are NOT required to touch the net)

# Net Faults

---

A player contacts any part of the net including net cables or net antennas.

- Not a fault if hair touches
- Not a fault if the ball pushes the net into the player.

A player gains an advantage by contacting the floor/wall cables, standards or first referee's platform.

# Net Faults

---

There is dangerous contact by a player with the floor/wall cables, standards or first referee's platform.

## Interference

- Contact with opponent with interferes with effort to play the ball.
- Intentional contact with playable ball under the net, and the opponent is attempting to play.

# Net Faults – Case Play 9.6.7 Sit A

---

A player

a) contacts the referee's platform

b) grasps the standard

c) touches the net cable between the net and standard.



# Net Faults – Case 9.6.7 Ruling

---

A player

- a) contacts the referee's platform - Legal
- b) grasps the standard - Legal
- c) touches the net cable between the net and standard. – Net Fault

Note: in a) or b), if player gains an advantage it is illegal.

# Center Line

---

A player may touch the floor across the center line with one or both feet/hands provided a part of the foot/feet or hand(s) remains on or above the center line. Contacting the floor across the center line with any other part of the body is illegal.

# Center Line Extended

---

A player may cross the extension of the center line **outside the court** at any time provided he/she does not interfere with play by the opposing team.

# Center Line Case Play 9.5.7

---

The LF on Team S and the RF on Team R are engaged in play at the net. Team S lands first with his/her foot partially across the center line. Team R then lands with a foot partially across the center line and on top of team S player's foot. The player on team S:

a) falls and/or stumbles and is unable to make a play on the ball falling near him/her.

b) falls and/or stumbles, but play is not affected as that player was not involved in the play on the ball.

# Case Play 9.5.7 - Ruling

---

The LF on Team S and the RF on Team R are engaged in play at the net. Team S lands first with his/her foot partially across the center line. Team R then lands with a foot partially across the center line and on top of team S player's foot. The player on team S:

a) falls and/or stumbles and is unable to make a play on the ball falling near him/her. – **Center line violation on Team R**

b) falls and/or stumbles, but play is not affected as that player was not involved in the play on the ball. – **Legal, play continues**

# Center Line Violation Signal

---

## Signal 2

Indicate the line where violation occurred by extending arm and pointing toward the line with the index finger.





# The Serve

---

RULE 8





# Serving

---

One hand, fist or arm.

Ball can be held or released.

5 seconds to contact ball after  
signal to serve



# Serving

---

Serve (like any attack) must pass between the antennas

Serve can hit the net



# Serving

---

Server shall serve from within the serving area and shall not touch the end line or the floor outside the lines marking the width of the serving area at the instant the ball is contacted for serve.

The server's body may be in the air over or beyond the serving area boundary lines, having left the floor from within the serving area.



# Re-Serve

---

Called when server releases the ball then lets it drop or catches it.

Each player may have one re-serve during a term of service.

If a sub replaces a server who has used a re-serve, the new server may still have a re-serve. [8-1-5]

# Re-Serve – Case 8-1-6

---

After the first referee's signal for service, the server :

- a) swings and misses the tossed ball
- b) swings, misses, and the ball contacts her shoulder
- c) lets the tossed ball drop to the floor
- d) catches a bad toss
- e) tosses the ball, then lets it drop without swinging at it, but it touches the server's knee as it drops to the floor

Ruling: ?

# Re-Serve – Case 8-1-6

---

After the first referee's signal for service, the server :

- a) swings and misses the tossed ball – re-serve
- b) swings, misses, and the ball contacts her shoulder – illegal serve
- c) lets the tossed ball drop to the floor – re-serve
- d) catches a bad toss – re-serve
- e) tosses the ball, then lets it drop without swinging at it, but it touches the server's knee as it drops to the floor – re-serve

Comment: in e) no attempt was made to play the ball.

# Re-Serve – Case 8-1-5

---

Player S1 is awarded a re-serve and serves two more points before being replaced by Player S2.

S2 is awarded a re-serve during his/her term of service

Ruling: ?

# Re-Serve – Case 8-1-5

---

Player S1 is awarded a re-serve and serves two more points before being replaced by Player S2.

S2 is awarded a re-serve during his/her term of service

Ruling: **Correct**

Comment: Each player is entitled to one re-serve during any one team's term of service



# Re-Serve – Case 8-1-6 Situation C

---

Server A recognizes that he/she is the improper server so tosses and catches the ball to force a re-serve.

Before the five seconds have elapsed, the proper server takes his/her place and makes a legal serve. They make a bad toss on the next serve and catch the ball.

Ruling: ?

# Re-Serve – Case 8-1-6 Situation C

---

Server A recognizes that he/she is the improper server so tosses and catches the ball to force a re-serve.

Before the five seconds have elapsed, the proper server takes his/her place and makes a legal serve. They make a bad toss on the next serve and catch the ball.

Ruling: **Illegal serve; loss of rally/point**

Comment: The improper server has already used up the proper server's re-serve privilege for that player's term of service.

# Re-Serve

---

A re-serve is considered to be part of a single attempt to serve.

No requests (e.g. time-out, service order, lineup, substitution, libero replacement, etc) may be recognized until after the ball is served.

# Signal for Illegal Serve

---







# Post Game



---

IT AIN'T OVER UNTIL THE PAPERWORK IS DONE

# Post Game Report on Arbiter

---

R1 completes the report

Report final match score

Note any significant game issues in comments section

				Time	Location	Gym		
9460		101441	REF 2	4/5/2022 Tue 5:00 PM	Volleyball, Boys Junior Varsity	Salinas High School, Gym	Salinas High School	Monterey High School
9819		101441	REF 1	4/5/2022 Tue 6:30 PM	Volleyball, Boys Varsity	Salinas High School, Gym	Salinas High School	Monterey High School
9398		101441	REF 2	4/7/2022 Thu 5:00 PM	Volleyball, Boys Junior Varsity	Alisal High School, Gym	Alisal High School	Soledad High School
9427		101441	REF 1	4/7/2022 Thu 6:30 PM	Volleyball, Boys Varsity	Alisal High School, Gym	Alisal High School	Soledad High School
11026		101441	REF 1	4/9/2022 Sat 8:00 AM	Volleyball, Varsity Tournament	Hollister-San Benito High School, Gym	TBA	TBA
9821		101441	REF 2	4/11/2022 Mon 5:00 PM	Volleyball, Boys Junior Varsity	Carmel High School, Gym	Carmel High School	Monterey High School
9826		101441	REF 1	4/11/2022 Mon 6:30 PM	Volleyball, Boys Varsity	Carmel High School, Gym	Carmel High School	Monterey High School
10992		101441	REF 2	4/13/2022 Wed 5:00 PM	Volleyball, Boys Varsity	Marina High School, Gym	Marina High School	Rancho San Juan High School
45942		BASO	R1	4/23/2022 Sat 8:00 AM	Mens VB, Varsity Tournament	Bellarmino College Prep, Gym	Bellarmino College Preparatory	TBA
45945		BASO	R1	4/23/2022 Sat 1:00 PM	Mens VB, Varsity Tournament	Bellarmino College Prep, Gym	Bellarmino College Preparatory	TBA
9535		101441	REF 1	4/25/2022 Mon 6:30 PM	Volleyball, Boys Varsity	Gilroy High School, Gym	Gilroy High School	Rancho San Juan High School
9472		101441	REF 2	4/26/2022 Tue 5:00 PM	Volleyball, Boys Junior Varsity	Carmel High School, Gym	Carmel High School	San Benito High School
9485		101441	REF 1	4/26/2022 Tue 6:30 PM	Volleyball, Boys Varsity	Carmel High School, Gym	Carmel High School	San Benito High School
9478		101441	REF 1	5/3/2022 Tue 5:00 PM	Volleyball, Boys Junior Varsity	Palma High School, Gym	Palma High School	Christopher High School
9479		101441	REF 1	5/3/2022 Tue 6:30 PM	Volleyball, Boys Varsity	Palma High School, Gym	Palma High School	Christopher High School
9472		101441	REF 1	5/4/2022 Wed 5:00 PM	Volleyball, Boys Junior Varsity	Seaside High School, Gym	Seaside High School	Watsonville High School
9473		101441	REF 2	5/4/2022 Wed 6:30 PM	Volleyball, Boys Varsity	Seaside High School, Gym	Seaside High School	Watsonville High School
11309		101441	REF 2	5/10/2022 Tue 7:00 PM	Volleyball, CCS (Playoffs Only)	Carmel High School, Gym	Carmel High School	TBA
46502		BASO	Lines	5/14/2022 Sat 11:30 AM	Mens VB, VARSITY-B	St. Francis High School-Mountain View, Gym	Monta Vista High School	Homestead High School
46501		BASO	R1	5/14/2022 Sat 2:00 PM	Mens VB, VARSITY-B	St. Francis High School-Mountain View, Gym	St. Francis High School-Mountain View	Mountain View High School-Mountain View
46514		BASO	R2	5/17/2022 Tue 6:00 PM	Mens VB, VARSITY-B	Mountain View High School-Mountain View, Gym	Mountain View High School-Mountain View	Campolindo High School
Event		101441		7/26/2022 Tue 6:30 PM	Volleyball Training Meeting One	Palma High School		
Event		101441		7/27/2022 Wed 6:30 PM	Football Meeting Two on Zoom	Your Laptop Computer or SmartPhone		



# Post Game Report on Arbiter

Game Report (Game: 9412)

Save Exit

Game	Date	Time	Sport	Level	Site	Status	Notes
9412	5/4/2022 Wed	5:00 PM	Volleyball	Boys Junior Varsity	Seaside High School, Gym	Normal	
Team		Score					
Seaside High School		<input type="text"/>					
Watsonville High School		<input type="text"/>					
Ref #	Official			Status			
REF 1	Lance Null			On Time			
REF 2	Larry Eady			On Time			

Comments



Save Exit

# Post Game Report on Arbiter

Game Report (Game: 9412)

Save Exit

Game	Date	Time	Sport	Level	Site	Status	Notes
9412	5/4/2022 Wed	5:00 PM	Volleyball	Boys Junior Varsity	Seaside High School, Gym	Normal	
Team		Score					
Seaside High School		0					
Watsonville High School		2					
Position		Official	Status				
REF 1		Lance Null	On Time				
REF 2		Larry Eady	On Time				

Comments

Any comments from the game would be listed here.



Save Exit



Have a Great  
Season!

---